

ART FOR YOUR KIDS

Building and Stimulating Minds
Since the Birth of Creativity

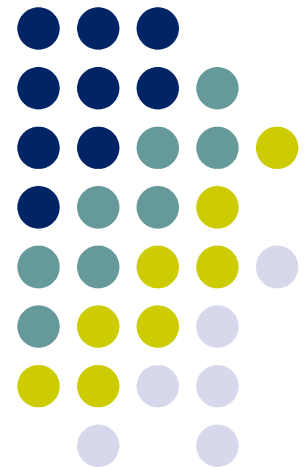

Common Stereotypes

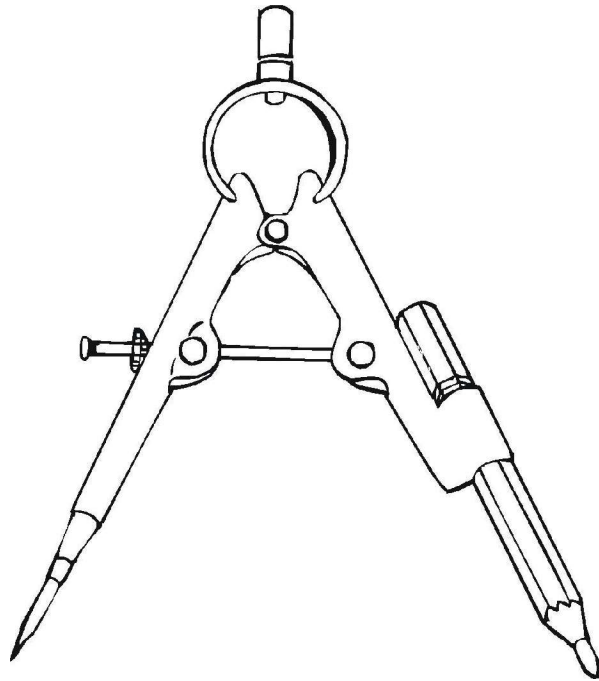

“Left Brain”

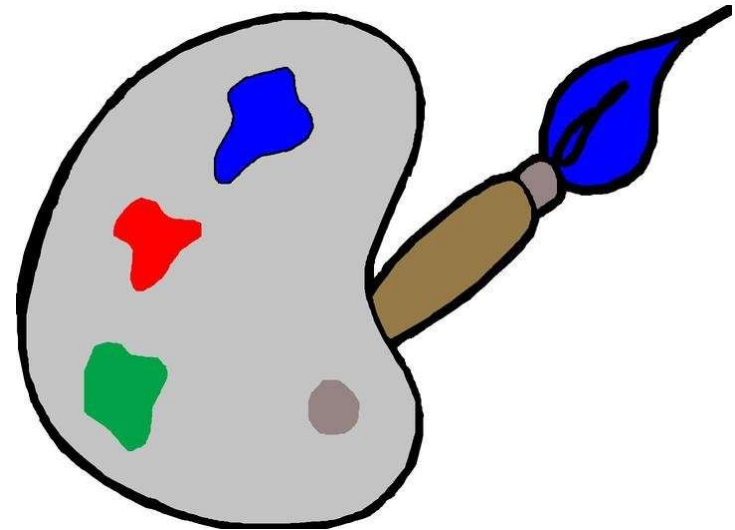

“Right Brain”

Economics—A Brief Overview



- \$4.85 million in created jobs
- \$134 billion in generated profit by nonprofit art agencies
- \$10.5 billion in income taxes

Benefits for Your Children



- 5. Creative and Critical Thinking
- 4. Enhanced Problem-Solving and Decision-Making Skills



SAT Scores of Students in the Arts

COURSE TITLE	VERBAL MEAN SCORES			MATH MEAN SCORES		
	2000	2001	2002	2000	2001	2002
<i>Art History/Appreciation</i>	517	518	515	518	518	517
<i>Studio Art/Design</i>	524	525	522	528	528	528
<i>Photography/Film</i>	526	527	524	526	526	526
Dance	514	512	509	510	510	508
Drama: Study or Appreciation	534	534	531	522	523	522
Music: Study or Appreciation	538	539	537	537	538	537
Music Performance	532	533	530	534	535	535
NO ARTS COURSEWORK	477	476	473	496	494	494

Sources: The College Board, Profile of College-Bound Seniors National Report for 2000, 2001, and 2002.



SAT Scores of Students in the Arts

COURSE TITLE	VERBAL MEAN SCORES			MATH MEAN SCORES		
	2000	2001	2002	2000	2001	2002
<i>Art History/Appreciation</i>	517	518	515	518	518	517
<i>Studio Art/Design</i>	524	525	522	528	528	528
<i>Photography/Film</i>	526	527	524	526	526	526
NO ARTS COURSEWORK	477	476	473	496	494	494
Drama: Study or Appreciation	534	534	531	522	523	522
Music: Study or Appreciation	538	539	537	537	538	537
Music Performance	532	533	530	534	535	535
NO ARTS COURSEWORK	477	476	473	496	494	494

Sources: The College Board, Profile of College-Bound Seniors National Report for 2000, 2001, and 2002.



More Benefits

- 3. Eloquent and Articulate Self-Expression
- 2. Improved Discipline and Self-Control
- 1. Boost in Confidence and Self-Esteem



What You Can Do

- **Seek** out additional resources online
- **Ask** school and state officials about arts education
- **Promote** involvement in and awareness of the fine arts at home
- **Encourage** the practice of the fine arts



Art: Building and Stimulating Minds since the Birth of Creativity





Works Consulted

- [Americans for the Arts](http://www.americansforthearts.com). 9 May 2004. 10 May 2004 <www.americansforthearts.com>.
- [National PTA](http://www.pta.org/). 4 May 2004. 7 May 2004 <<http://www.pta.org/>>.
- [National Art Education Association](http://www.naea-reston.org/news.html). 17 Feb. 2004. 8 May 2004 <<http://www.naea-reston.org/news.html>>.
- Deasy, Richard J., ed. “Critical Links: Learning in the Arts and Student Academic and Social Development.” [Arts Education Partnership](http://www.aeparts.org/PDF%20Files/%20CriticalLinks.pdf). 2002. 7 May 2004 <<http://www.aeparts.org/PDF%20Files/%20CriticalLinks.pdf>>.

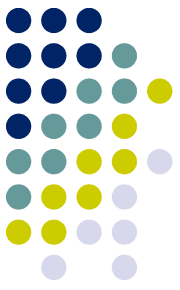

Additional Works Consulted

- ArtsEdge. 8 May 2004. 8 May 2004 <<http://artsedge.kennedy-center.org>>.
- Arts Education Partnership. 29 April 2004. 7 May 2004 <<http://artsedge.kennedy-center.org/aboutus/>>.
- Kim, Jane. “Express Yourself.” Education and Political Science 59. Course home page. Spring 2002. Macalester College. 10 May 2004. <<http://www.macalester.edu/courses/educ59/PIE/Kim-%20PIE.htm>>.
- “No Subject Left Behind: A Guide to Arts Education Opportunities in the 2001 Education Act.” Americans for the Arts. 2004. 9 May 2004 <http://www.artsusa.org/pdf/no_subject_left_behind.pdf>.
- “Erikson Psychosocial Stages Summary.” Human Development. Course home page. Fall 2003. U of Illinois. 8 May 2004 <<http://www.psych.uic.edu/hd/StagesSummary.pdf>>.